

## RADIUS AND ANGLE WHEEL DRESSER - RDC280

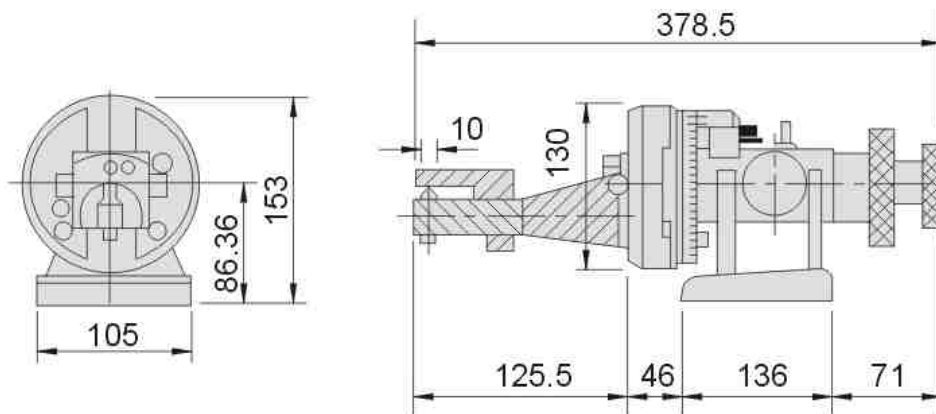

6001/04/280

### Wheel dressing applications



**Use :** On surface grinding machine for dressing grinding wheels into various cross sections of flat or curved shapes.

### Features :

- Hardened steel tool construction.
- Center height :  $\approx 86$  mm
- Max horizontal translation : 90 mm
- Max grinding wheel convex radius : 60 mm
- Max grinding wheel concave radius : 150 mm
- Max grinding wheel dressing diam : 279 mm
- Weight : 9.5 Kg