

STAINLESS STEEL PRECISION VISE FOR EDM – WCV280

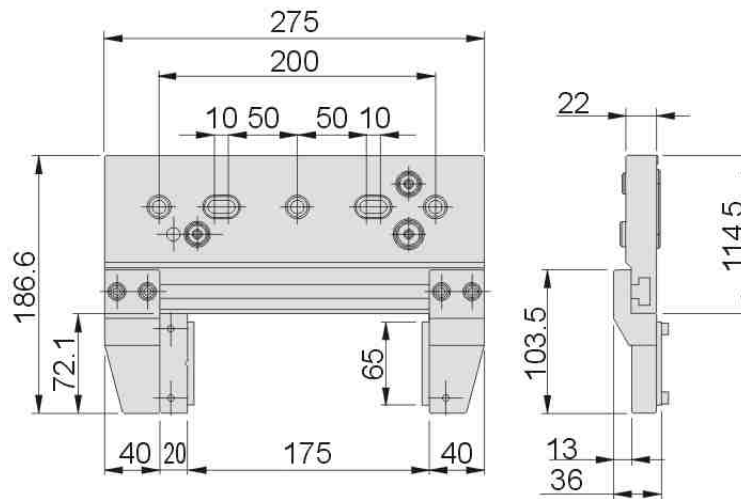
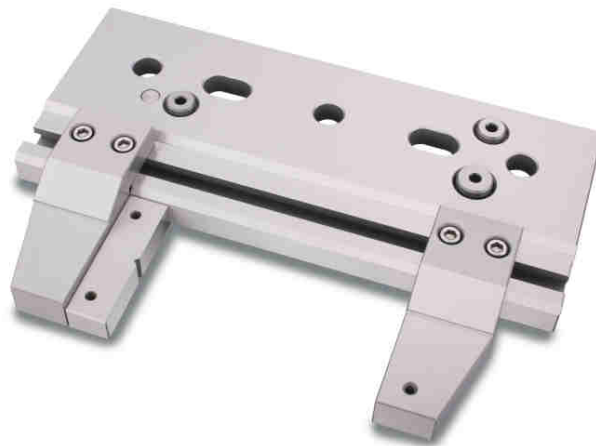

Dimensions (mm)				
Part Number	Jaw opening	Jaw width	Jaw height	Weight Kg
1002/31/80	0-175	22	72,1	6

Use : EDM

Features :

- High quality stainless steel
- Cryogenic hardening , hardness : 45-55 HRC
- Ball bearing design and 3 axis fine setting
- Parallélism : 0.003/100 mm
- Squareness : 0.005/100 mm