

PUNCH FORMER AND WHEEL DRESSER – ARP76-2

Référence
6001/07/2

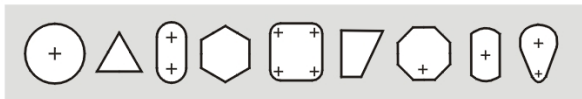

Punch Forming Applications

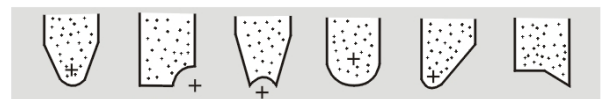

Wheel Dressing Applications

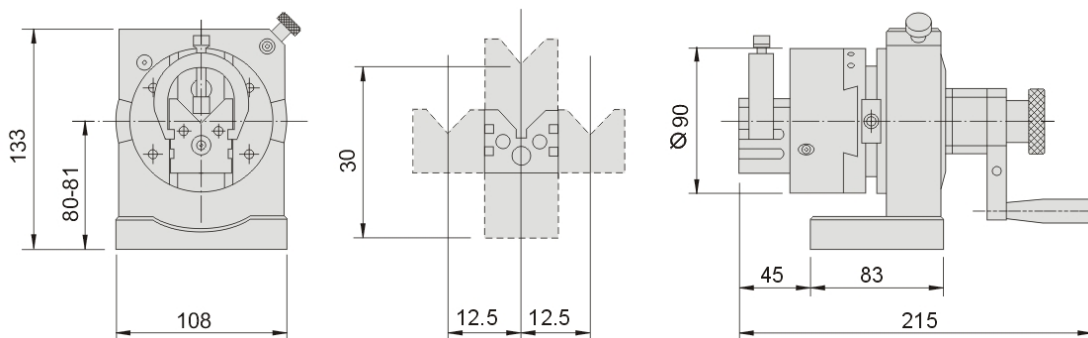

Use : On surface grinding machine ARP76-2 is suitable for manual processing of various shapes on punches and grinding wheels.

Features :

- Hardened tool steel construction
- Center height : 80-81 mm
- Indexing division : 24 every 15° ±10''
- Intermediate angles settled with gauge blocks (sinus principle).
- Vertical travel of V-block : 30 mm
- Side travel of V-block ± 12.5 mm
- Clamping dia of V-block : Ø 4 - 30 mm
- Clamping accuracy (50mm) 0.005 mm.
- Max wheel dressing dia : 200 mm
- Max radius arc dressing :
 - Convex R = 48 mm.
 - Concave R = 100 mm.
- Weight 8.6 Kg
- Supplied without diamond tool dresser.
- Options : sine base.